

# Enterprise Biology Software: II. Education (2001)

ROBERT P. BOLENDER

*Enterprise Biology Software* Project, P.O. Box 303, Medina, WA 98039-303 USA  
<http://enterprisebiology.com>

---

## Summary

An enterprise approach to biology was developed by combining biology, mathematics, and technology. The overall strategy of the project was to combine research and education in ways that could accelerate learning and discovery. The previous paper summarized progress toward developing and using a mathematical platform for research biology. This paper describes the three courses and a short story included with the software. It considers the development of a general platform for biology education, one capable of increasing productivity and supporting a wide range of biology courses, students, and professionals.

The *Enterprise Biology Software* included a short story, three courses (biology, mathematics (stereology), technology), three databases (courses, literature, tutorial), a template for assembling new courses, electronic data entry forms for research publications, and support material. The short story and the courses were written specifically for undergraduate biology students. Taken together, the courses present biology as a fusion of subject matter, mathematics, and technology.

---

## Introduction

The challenge in defining an enterprise approach to biology education was to imagine what biology might be like in the future so that it could be built and tried out today. Implicit in such an approach was the optimization of outcomes, as applied to students, faculty, administrators, and the scientific community. This included improving the efficiency of our current approaches and introducing new ones, by applying mathematics and technology.

There is an inescapable truth. Technology will transform biology from soft science into hard one. Mathematics has already played a central role in the extraordinary success of genetics and molecular biology, setting a standard for the other disciplines to follow. However, the transition to a mathematical base for most of the other disciplines in biology has been disappointingly slow. Thumb through the textbooks being used by undergraduate biology students today and you will discover vast encyclopedias instead of imaginative guides to learning and discovery (Dunbar, 1995). For the most part, mathematics is nowhere to be found.

In a textbook, the information just sits there as an implacable mass and the reader is expected to interact with it in ways that promote learning. A better approach – for everyone – might be to store the same information in a highly interactive framework, one that could be readily defined and redefined by the reader. We would still have an encyclopedia, but now it would be more user-friendly. In effect, technology can replace the static pages of the textbook with highly interactive computer screens. The **Enterprise Biology Software** frequently employs this option.

Biology is a science that has been divided and subdivided into many disciplines over the years. Although this process of division has contributed importantly to the development of the science, it has also increased the complexity of biology education. Today, most biology courses exist as stand-alone units with few direct connections to other courses. Moreover, biology – being a largely a descriptive science – is routinely presented to students as a collection of facts or as an historical account of research accomplishments. Courses consistently focus on the past, not on the future.

Jump to the future. Within an enterprise framework, biology becomes a single topic stored in multiple and connected databases. Disciplines continue to be distinct entities, but they are stored and managed together. Instead of writing a biology course from scratch, it is assembled by selecting a course template and populating it with the appropriate elements. A curriculum becomes defined by the content of the databases and the courses derived therefrom. The connection between research and education depends on sharing responsibility for the biology literature, which also becomes stored in databases. Mathematics and technology are everywhere.

The purpose of this paper was to explore the possibility of accelerating learning and discovery in biology by applying an enterprise approach to education. The first course (human biology) introduced biology, the second (mathematics) explained the discovery platform, and the third (technology) defined the enterprise approach. A short story included a systematic account of the process used to design and implement the enterprise approach.

## Methods

### Strategy

The enterprise approach called for a strategy that would accelerate learning and discovery. In short, this meant increasing productivity across the enterprise. To this end, the plan described earlier for research was applied to education as well. It consisted of going either from simple to complex or from complex to simple – selecting a best method at each step of the process.

### Human Biology Course

To illustrate this approach, a course in human biology was assembled for undergraduates. Although the content of the course followed a traditional outline, consisting of lectures followed by quizzes and exams, technology was applied throughout. For example, memorization was retained as the central measure of performance, but the reliance on this traditional method of learning was reduced by focusing on basic principles and using technology to speed memorization. After increasing student skills and performance in the traditional areas, the course shifted its focus to discovery as a new learning strategy. As defined here, discovery required an introduction to biology as a mathematical science and the development of a new set of learning skills designed specifically for exploring the biology literature. In short, these new applications of technology were aimed directly at increasing student productivity by developing research skills. Measures of productivity were expanded to include performance (grades), skills (managing complexity, exploring with technology), teamwork (solving problems as a group), and service (electronic data entry, technology transfer).

The plan for developing the biology courses followed several guidelines: (1) identify the basic elements of a biology course, (2) develop a common template for courses, (3) explore new ways of using technology to speed learning and discovery, (4) set a high standard for student performance, (5) identify ways of combining education and research, and (6) include students in the development process.

**Basic Elements:** The basic elements of a biology course were identified as facts, images, connections, assignments, and quizzes. These elements were stored as tables in the courses database and used to assemble a course. The relationships (connections) between the database tables were defined by a logical model – similar to the one used by the research model (Bolender, 2001). It consisted of a hierarchical backbone onto which facts and images were mapped (figure 1).

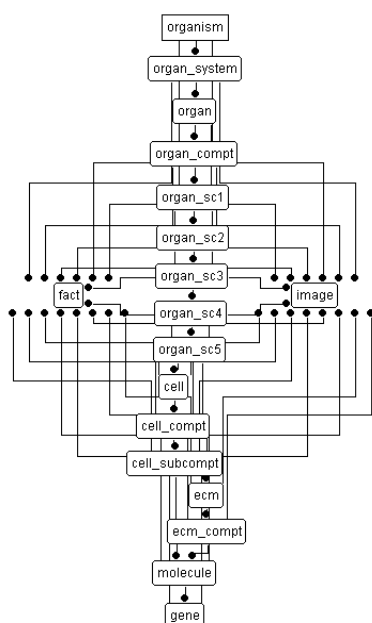

Figure 1. The logical model identifies entities (boxes) and relationships (connecting lines).

**Template for Biology Courses:** A course template included a user interface and reusable elements defined by the courses database. This meant that assembling a new course could be reduced to selecting data from the database and adding new material unique to that course. Lecture slides for the human biology course

were written first in PowerPoint as slide shows and then stored as wmf files in the facts table. Each lecture was assembled by combining slides, facts, images, and connections – using tools provided in the appendix.

**Lectures:** The human biology course had thirty-eight lectures, each of which included lecture slides, assignment, quiz, and usually one or more exercises. The exercises, for example, included word roots, images (viewing, memorizing, labeling, identifying), browsers (image, fact, hierarchy, word root, epithelium, skeleton, joint 1, muscle, joint 2, nerve, artery, brain-cord.), animations, and review questions (fact, image, histology, matching).

**Browsers:** The browsers (listed above) included tables of facts and images connected to one another, according to the rules of relational databases. They allowed a beginning student to explore even complex relationships of structure to function with a level of comfort usually reserved for advanced students or professionals. This serves as an example of how technology can increase student productivity by providing learning tools more powerful than those currently being offered in biology textbooks.

The brain browser, for example was based on a relational model that named and defined the relationships among more than a thousand parts. It was, however, both a learning and research tool. Without it, for example, populating a literature database with brain data would be practically impossible. In effect, the brain and hierarchy browsers served as “playbooks” for entering data into the literature database.

Indeed, relational models can come to the aid of students at all levels. For example, a first year medical student in gross anatomy is routinely faced with the task of sorting out many complex relationships of structure to function. The convoluted relationships among muscles, joint actions, and nerves can be particularly challenging because so many of the relationships are many to many. The joint 1 browser, which was used routinely by undergraduate students, made such difficult tasks relatively easy. For example, undergraduates developed a good understanding of complex relationships among structures and functions by working out simple clinical problems. This introduced them to art of clinical diagnosis – not by tediously thumbing through medical reference books, but by simply running a browser.

**Practice Exercises:** The assignments often included exercises that were either part of the human biology course or taken from one of the other courses. As the course progressed, students were introduced to the research process first by looking for patterns (basics, change, data) and then by exploring the biology literature (standardize, original data, new data).

**Quizzes and Exams:** Each lecture included a short answer quiz consisting of ten questions. Questions were taken from the lecture or written so that they could be answered by applying a technology tool. When all the questions were answered correctly, the program responded by identifying two of the questions that would appear on the midterm or final exam. To encourage students to work together when taking these quizzes, questions were often made too difficult to be answered working alone. A further incentive for working together consisted of offering students ten bonus points on the final exam in exchange for a class average of 85% on the midterm. By asking students to do more with technology than might otherwise be expected without it, productivity was increased incrementally with each software upgrade.

## Mathematics Course

The mathematics course dealt primarily with stereology, a special type of geometry. It explained how to collect data with unbiased methods, to connect data across a hierarchy of size, and to move data across n-dimensional space. These skills were fundamental to the larger task of assembling a mathematical platform for biology. Such a platform became useful to beginning students because it allowed them to explore and learn the fundamentals of dealing with complexity in biology.

A primary goal of the course was to translate theory into practice. For example, by developing generalizations that could be applied widely to research papers in the biology literature, students learned what to look for in a scientific paper. In turn, this skill became essential in the technology course when students were introduced to electronic data entry. Another example was the hypothesis wizard. It offered one of the best experiences for students to sharpen their skills as informed critics. The exercise showed them how to take a hypothesis stated in words and turn it into a balanced equation. Moreover, they learned that such an equation defined – explicitly - both the question and the answer of an experiment. The equation also focused a spotlight on the assumptions of an experimental design – stated or unstated.

Notice the strategy used by the hypothesis wizard of going from complex to simple. Reading a research paper in biology is especially difficult for a beginner because the methods of collecting and interpreting the data are largely unfamiliar. In effect, the methods introduce a largely impenetrable barrier of complexity for the uninitiated.

Question → Methods → Answer

The hypothesis wizard simplifies the process of reading a paper by asking if the answer is consistent with the question. In effect, this made it possible to bypass the methods for the moment and focus directly on

the main claim of the paper. This is the exactly the approach often used by the most experienced reviewers of papers submitted for publication in scientific journals.

Question → Answer

The course included sixteen lectures and twelve labs. An assignment screen included a brief summary of each lecture and lab. Lectures and labs were presented as PowerPoint slide shows and usually followed by hands on exercises and worked examples. The strategy of the course consisted of introducing the methods as modules and then exploring ways of assembling the modules into solutions for specific problems. The current course upgrades a previously published program (Bolender, 1992).

The quizzes (midterm and final) were taken by several students working as a group. Based on a prior agreement with all students, the exam booklets were accepted only after all the questions had been answered correctly. This meant that all students received an A (4.0) in this course, because the best outcome was the only option. Copies of the midterm and final quizzes were included in the software to illustrate some of the things the students learned to do.

## Technology Course

The technology course defined the enterprise model for biology – as three models (qualitative, quantitative, and relational) combined into one. Here the goal was to use technology to create a springboard into the unknown. To this end, the biology literature was transferred to a mathematical platform where technology could become that springboard. The mathematical platform selected for biology emulated those of the physical sciences. However, it required a special interface – built with mathematics and technology – to generate biological data that displayed properties similar to those of physical data. Once obtained, however, these new data could be used to quantify relationships between two or more parts, as described in the companion paper (Bolender, 2001). In turn, this technique of connecting biological parts created a second mathematical platform for biology. This one defined relationships among the parts explicitly as networks of equations, which could be used to predict data across the networks from a single seed value. The point here was to test the feasibility of using these networks as a way of gaining access to the mathematical organization of biology. Such access is expected to trigger opportunities for exploring the deeper relationships of biology to the laws of nature. Understanding such relationships becomes one of the many prerogatives of a mathematical biology.

The course also explored ways of using technology to increase productivity in education by generalizing biology across disciplines. To this end, an education model was described using the human biology course as an example. In turn, the model could be expanded into a strategy for connecting research and education by sharing similar goals and resources.

The course included nine lectures, assignments, lectures, labs, work screens, simulators, and fifteen case studies - but no quizzes. Lectures were presented as PowerPoint slide shows and followed by exercises. The assignment screen included a brief summary of each lecture. The purpose of the course was to show how the components of an enterprise approach were assembled into a fully functioning system, including examples of its application.

## Data City – A Short Story

One of the challenging problems facing education today is figuring out how to improve productivity with technology – across the board. Everyone is involved – all the way from students to superintendents and deans. The problem in applying technology effectively is that it ultimately requires an enterprise approach to optimize outcomes. Although the corporate world has embraced this approach enthusiastically as a way of increasing productivity, education enjoys few of the incentives associated with a competitive market place. In contrast to corporations, survival in education does not depend decisively on the resourceful application of technology. In time, however, even education will submit to optimizing outcomes because that's the point of embracing technology.

Implementing an enterprise approach is an expensive and frustrating task – at best! The problem with the approach is that it is impossible to predict or assess the effectiveness an enterprise system until long after it has been built and tested. A general explanation for this dilemma is that enterprise software exhibits emergent properties that cannot even be imagined at first. However, the lessons learned during the writing this software package might offer some helpful insights. This was the purpose of the short story.

The story started with an invitation to invent the future by making a journey from biology today to what we might imagine it would be like tomorrow. In short, it was a story about what happened when mathematics and technology were applied to biology - a largely descriptive science. The story was included in the software because the process of journeying into the unknown was just as remarkable as the destinations.

The story included four chapters and eight quizzes. Quizzes were included to give the reader an opportunity to explore the new ideas and to prepare for what was to come next. The theme of the story was ambitious by design - start with nothing and end up with everything. Although at first this seemed an unlikely premise, it turned out to be the simplest approach.

## Management Tools

The appendix included tools for maintaining the courses and databases. An enterprise approach – even a small one – required a high degree of flexibility and administrative support.

---

## Results

### Software Package

The *Enterprise Biology Software* contained 1.2 GB of programs, files, and databases. This included 352 programs, 528 files, 1,500 images, 1,200 short answer questions, and 3 relational databases. The software package included installation programs that first installed files in directories and then automatically set up a client-server facility on the target PC computer.

### Human Biology Course

The enterprise software demonstrated that a biology course could be assembled from a set of elements common to all biology courses. Moreover, by applying the rules of relational databases, the course elements could be combined in ways that simplified the task of finding relationships and patterns in biology. For example, the images screen combined pictures, facts, and the biological hierarchy into a simple resource for exploring visual patterns in biology. It served as a useful tool for building a visual memory of biological images – quickly. In general, browsers moved reference data from textbook-like tables to a computer screen where otherwise complex relationships could be viewed and explored with ease. An example of this is the joint 1 browser. It linked joint action to muscle to region to nerve to nerve roots (major, minor, infrequent). By combining data from several tables, it was possible for a beginner to explore a wide range of complex relationships – typically the territory of advanced students and professionals. In effect, this exemplified a central theme of the course – that of using technology in ways that encouraged students to become comfortable in dealing with complexity.

The human biology course was written specifically for undergraduates. However, it can be readily reconfigured into other biology courses - such as high school biology, advanced histology (for graduate, medical, and dental students), human pathology, etc. The course included thirty-eight lectures, assignments, exercises, simulators, tutorials, and quizzes. Here technology was used extensively to create a new environment for students – one that offered experiences quite unlike those they currently enjoy with either textbooks or lectures.

The appendix included a tutorial for producing biology courses. It began with instructions for designing a new course and ended with directions for producing a CD that could be handed to students. The course template consisted of elements typically found in textbooks, but packaged as technology modules that could be added to a standard user-interface. In effect, the exercise offered a technology palette that a teacher could use to “paint” a modern biology course. Notice, however, that the teacher retained full control of the information content of the course by having administrator level access to the user-interface and databases.

### Mathematics Course

Fundamental to an enterprise approach is the importance of being connected – well connected. The mathematics course looked at research data in biology with the view of connecting them across a hierarchy of size – extending from individual molecules to whole organisms. The course identified data collected with unbiased methods as the best for making connections and explained how to recognize and collect such data from biology.

The mathematics course began by showing how to collect data from images of sections taken from biology. It then explained how to move these data across dimensions and into configurations that provided unambiguous results. Careful attention was also given to justifying the purpose and practice of unbiased sampling methods. In effect, the course suggested grounds rules for identifying the “best” papers in the biology literature for this project.

## Technology Course

The course began by defining enterprise biology as the conjunction of three models: qualitative, quantitative, and relational. The point of the course was to define a mathematical framework for the biology literature, one that could serve as a springboard into the unknown. Using this new framework, the student quickly learned that discovery depended – decisively - on creating new data from old. The course continued from this observation with examples of how an enterprise approach to biology served to define new categories of questions and answers.

The course explained the implementation of a relational model for the biology literature database, where seven rules and three models served as guidelines. The hierarchical model for the biology literature included two major components: (1) lists of structures located within each of sixteen hierarchical levels, and (2) numerical data for structure and function. Data entry consisted of assembling a structural hierarchy and then mapping the numerical data to the appropriate location. A separate hierarchy was assembled for each control and experimental data point (time point). With this approach, data could be compared within individual experiments or across all experiments. Detailed directions for data entry were included in the appendix of the software.

## Data City – A Short Story

The story explained how one could invent the future of biology by using imagination to build a data city. The story included four chapters. Chapter 1 introduced Data City and explained how to use it; Chapter 2 approached the quantitative core of biology by peeling away layers of complexity; it then explained how to design the buildings of Data City; Chapter 3 used these buildings to explore the underlying principles of biology; Chapter 4 related these principles to laws of nature. In effect, the story shared an extremely well hidden secret with the reader. It showed that the biology literature contains a vast reservoir of new information sitting just beyond our reach. The secret of the short story was that it demonstrated ways of extending our reach far enough to access these new levels of information.

## Appendix

The appendix included tools for maintaining the courses and databases. It provided a realistic view of what it takes to build and support an enterprise approach to biology in an academic setting.

---

## Discussion

This project began by imagining what biology might be like in the future and then proceeded to try out that future now. The *Enterprise Biology Software* served as the test vehicle. It included a collection of programs, files, images, simulators, animations, questions, and databases. The purpose of this paper was to illustrate ways of using this new technology to increase productivity in education.

## Productivity

In recent years, technology has been directly responsible for the increases in productivity seen throughout the corporate world. These gains demonstrate the willingness of governing boards and executives to reinterpret their traditional business models as information models. Implicit in these new information models is a commitment to look at everything as if for the first time – in other words - to make a fresh start. This is the demand of an enterprise approach.

Throughout this project, we have explored ways of increasing productivity in biology by making traditional approaches more efficient and by benefiting from a new information model. However, moving education – as an institution - to an information model may not happen for some time. Since the application of



technology in education fails to reach the status of being mission critical as it does in business, allocating resources for reinventing education as an information model cannot be easily justified. If education is already optimized as a traditional institution, then the introduction of technology might be more disruptive than helpful. Indeed, this may help to explain why the application of technology to education has largely failed to produce the expected widespread gains in productivity. Pasting technology onto an old model simply does not work – a lesson only recently learned by the corporate world.

To escape this present reality, the *Enterprise Biology Software* moved education abruptly into the future. It reinterpreted traditional biology as an information model and enhanced productivity by optimizing outcomes. Why? In the future, students comfortable with technology and complexity will enjoy a competitive advantage in an information economy. Indeed, information management will become just as mission-critical to a student as it is to a large corporation. The clock is ticking. In the persistent absence of this enabling technology, students will be forced – by necessity - to question the status of our traditional institutions as the foremost centers of excellence in education. In time, discontent will turn normally agreeable students into difficult customers enthusiastic for something better. When this happens, competition will promptly do for education what it has already done so well for corporations.

**Students:** In education, grades serve as the principal indicator of productivity. The better the grade the better the productivity. A strategy used in the *Enterprise Biology Software* was based on an unusual but testable assumption. If A were the only grade offered, then all students receiving a grade would be A students – by default. In the traditional grading system, A is offered along with B, C, D, and F (or some similar scale). If we assume - a priori - that excellence is an optimal goal of education, then the first grading system requires excellence, whereas the second one makes it optional. Here the strategy of the enterprise approach was to increase student productivity by simply removing the temptation of accepting a grade less than an A.

The results of this strategy look promising. In the first year of the human biology course, roughly 15% of the students left with an A. After five years, however, more than 50% of the students received an A. Over time, the students had discovered ways of using technology to learn more in less time and to get a better grade. In the mathematics course, students were offered an A in exchange for answering all the questions on the midterm and final quizzes correctly. For both the midterm and final, all students eventually made the grade (the test booklet had to be returned to the students usually only once for each quiz).

Although student productivity could be increased by improving the efficiency of memorization and changing the focus of the grading system, the memorization model seemed to impose a practical limit on productivity. Some students were simply much better memorizers than others. This meant that productivity gains would have to be found elsewhere. By simply changing the definition of productivity to include memorization *and* discovery, productivity becomes a measure of what students can remember and what they can do. This new definition guided the design of the current software package.

What happens when a discovery model is added to biology education? It creates an opportunity for students to contribute directly to the scientific community by generating new research data from old, discovering new connections within biology, and helping to build the foundations of a modern biology (e.g., via electronic data entry). If this new approach works as imagined, then increases in student productivity can be transferred directly to the scientific community. Moreover, as students become comfortable with data from the biology literature, they become informed consumers and producers of knowledge. The point is simple. Put discovery tools in the hands of bright, imaginative young people and you prepare them to explore the unknown.

To this end, software was written for electronic data entry that can be used by undergraduate students to enter data from research publications into the biology literature database. The new tools offer a cost-effective way of introducing information technology into a research laboratory, one that would allow students to mentor and - in their turn - be mentored. More importantly, if undergraduates are successful at introducing electronic data entry into labs, then investigators might introduce the technology to colleagues and eventually to the governing boards of professional societies and journals. In effect, students would increase their productivity by making a fundamental and long-term contribution to their scientific community.

**Faculty:** The software saved time. Once the programs were installed, the undergraduate biology course more or less ran itself – except for giving the lectures and exams. However, getting the software installed remained a challenging task – year after year. Regrettably, the author could not write an installation program that worked uniformly well on all PC computers – at home and at the university. The immediate but frustrating solution to the problem was to provide online technical support to a class of more than four hundred students. With this release, however, the installation problem is finally solved by using the new Windows Installer® program from Microsoft. The Installer program automatically adapts to the operating system it finds on a computer.

The task of managing a biology course was simplified by developing a set of administrator tools. All the course elements stored in database tables can be changed (added, deleted, and updated). Since the original PowerPoint files (ppt) for the human biology course were included with the software, individual lecture slides can be modified with PowerPoint and readily saved as new files (wmf).

**Curriculum:** The enterprise software scales all across biology – in both research and education. This means that the framework described for the human biology course can be applied across all biology courses. For example, the basic science courses in medical and dental schools are especially well suited to an enterprise approach. To illustrate this point, the data entry screen used for the facts table included a checklist for the basic medical sciences, including anatomy, pathology, physiology, biochemistry, molecular biology, genetics, immunology, pharmacology, and microbiology. This approach provided a common data source with connections across all courses and addressed two perennial problems frequently reported by medical and dental students in their course evaluations - duplication and inconsistency. With a common resource, everyone would know where and when what was being taught. All updates and improvements would be shared equally by all participants in all courses. In effect, a modern basic science curriculum could be defined explicitly as a function of facts, images, connections, etc. – as illustrated by the human biology course.

## Concluding Comment

The *Enterprise Biology Software* addressed issues fundamental to moving biology into the Information Age. It identified key problems in research and education and then supplied software to suggest workable solutions. This was the strategy used to demonstrate the effectiveness of an enterprise approach to biology.

## References

- Bolender, R. P. QM2000 Stereology Software, Version 1.0. 1992 © Robert P. Bolender and the University of Washington.
- Bolender, R. P. 1993-1997 Human Biology Software © Robert P. Bolender and the University of Washington.
- Bolender, R. P. Enterprise Biology Software: I. Research. 2001 In: Enterprise Biology Software, Version 1.0. © Robert P. Bolender.
- Dunbar, R. The Trouble with Science. 1995 Harvard University Press, Cambridge, MA.

Saturday, December 07, 2002  
C:\EBiology\paper2.doc